

HEAD DETAIL

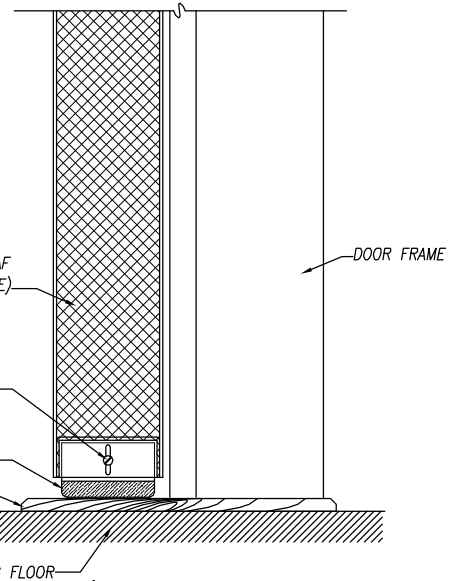

SILL DETAIL

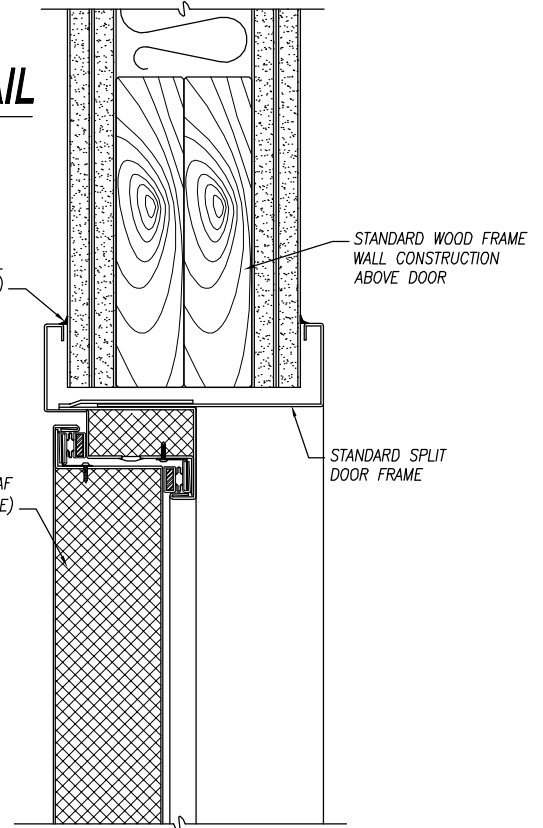
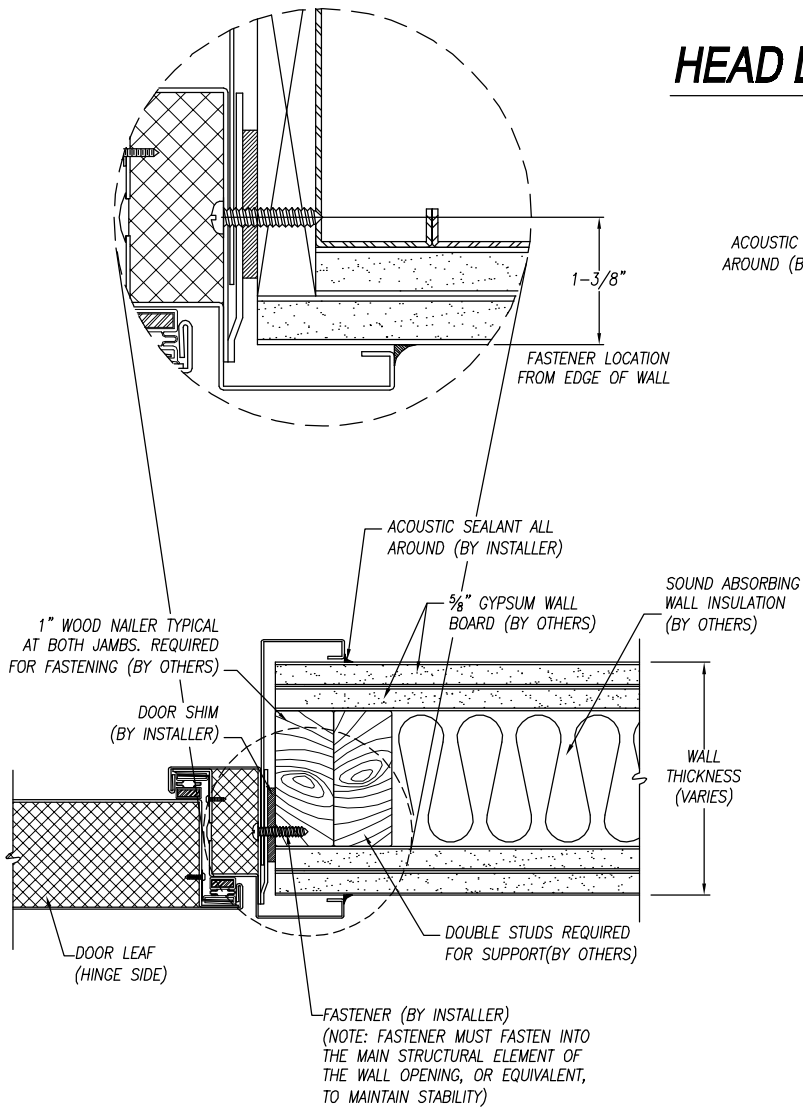

JAMB DETAIL

WOOD FRAME WALL INSTALLATION REQUIREMENTS

PROJECT:		TYPE:	
SUBMITTED BY:	DATE:	ISSUE:	
APPROVED BY:	DATE:	DRAWING No.:	
SHEET:			

Noise Barriers, LLC
 2001 Kelley Court
 Libertyville, IL 60048
 Phone: 847-843-0500
 Fax: 847-843-0501
 www.noisebarriers.com